

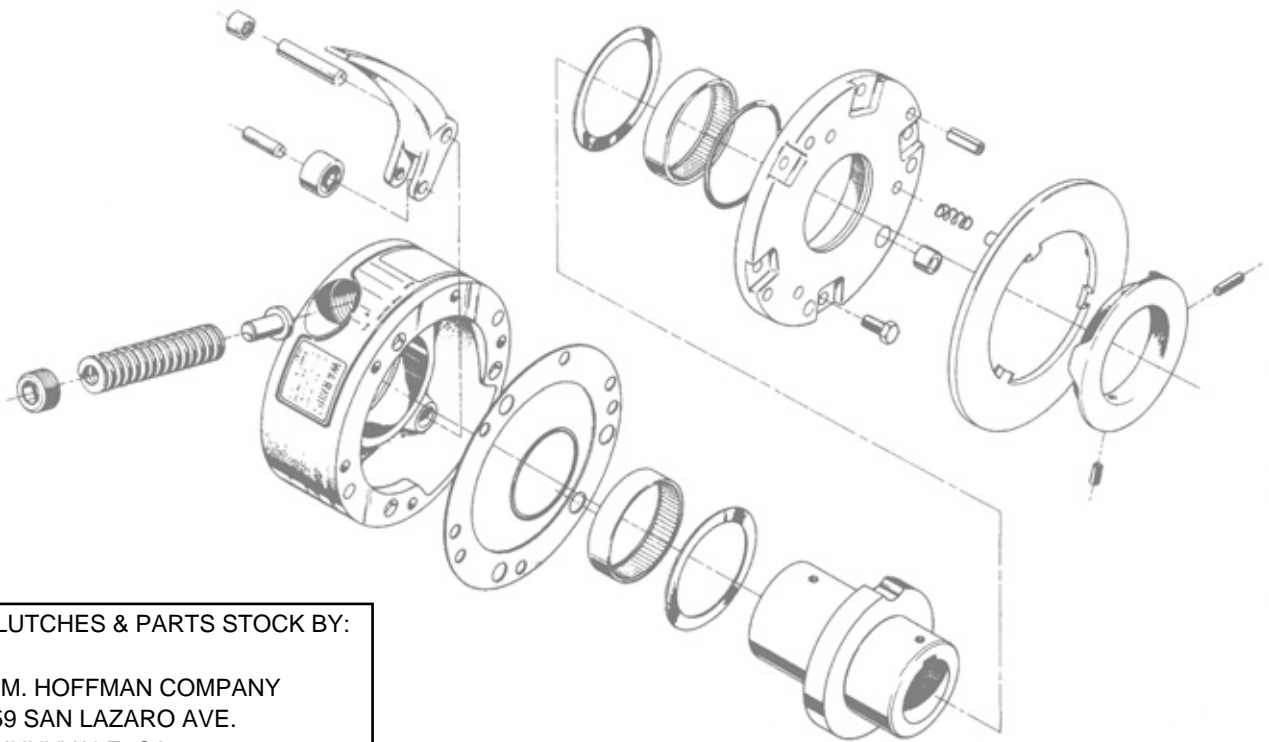

SERVICE MANUAL

TORQ-GARD™ OVERLOAD CLUTCH



CLUTCHES & PARTS STOCK BY:

R.M. HOFFMAN COMPANY
159 SAN LAZARO AVE.
SUNNYVALE CA 94086

CALL: 408 739-6580
FAX 408 735-1158

ORDER ON LINE:
WWW.RMHOFFMAN.COM



The Driving Force in Automation

WARNING

This is a controlled document. It is your responsibility to deliver this information to the end user of the CAMCO/FERGUSON product. Failure to deliver this could result in your liability for injury to the user or damage to the machine. For copies of this manual call your Customer Service Representative 800-645-5207.



torq/gard™

mechanical torque-limiting overload clutch

Installation–Operation and Maintenance Instructions

1. Read your Torq-Gard Installation-Operation Instructions thoroughly before operating the unit, for your safety and the protection of your equipment.
2. Double check to be sure the power is off and cannot be turned on while working on the equipment.
3. Electrical power should be disconnected at the fuse box, circuit breaker or motor starter.
4. The Torq-Gard Clutch is designed to protect your machine and will not protect against bodily injury.
5. Keep all objects such as hands, clothing, tools, etc. away from rotating or moving parts.
6. Use safety glasses or equivalent to protect your eyes.
7. Do not manually re-engage the Torq-Gard Clutch. (Refer to "Automatic Reset" instruction.)
8. Do not adjust the torque while the clutch is disengaged. (Refer to "Torque Setting" instruction.)
9. Do not exceed the recommended maximum RPM. (Refer to Torq/Gard Rating Chart.)
10. The detector mechanism must electrically disconnect the prime mover at the recommended RPM settings. (Refer to "Overload Detection" instruction.)
11. Shaft mounting set screws must clear the mounting bosses or the clutch will not release upon overload. (Refer to "Mounting the Torq/Gard" instruction.)
12. Shaft and detector mounting set screws must be tight and the recommended number used. (Refer to "Mounting the Torq/Gard" instruction.)

The above list includes major safety points to be observed, but should not be considered as limiting in safety precautions to be followed.

Operating Principle

Torq/Gard Overload Clutches help protect the entire drive train of your machinery from damage due to excessive torque generated by overloads and jamming. The torque is adjusted by turning the single hex-socket head control which adjusts the Torq/Gard Clutch precisely to any setting within its load range. A spring-loaded cam follower seated in a single hub cam detent causes the hub and clutch body to rotate as a unit. The two point contact of the follower produces equal forces within the cam detent, minimizing the effect of "breathing", found in conventional clutches. When the pre-set torque limit is exceeded by an overload condition, the follower is instantly released from the cam detent, disconnecting the hub from the body. Either the hub or the body may be used as the input or output.

NOTE: During overload, the Torq/Gard produces a loud audible report, which is a normal operating characteristic of the clutch.

In direct coupled applications, the modular designed Torq/Gard can be used with Browning Ever-Flex Couplings or Chain Coupling Kits, without modification to the clutch or couplings. Split taper bushings are available for the coupling output.

Browning Torq/Gard single strand sprockets, for No. 40, 60, 80, and 100 ANSI Standard Roller Chain Drives, mount directly to the clutch.

Browning Torq/Gard Gearbelt Pulleys are also available for 1/2" Pitch Belts.

Before mounting the clutch on the driving or driven shaft, your choice of coupling or sprocket should be attached to the Torq/Gard Clutch.

Sprocket Installation

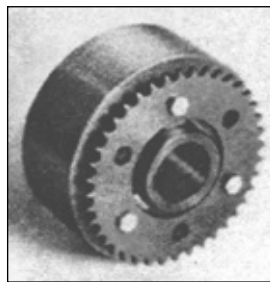

Browning Torq/Gard Single Strand Sprockets register with the drilled and tapped mounting lugs on the adapter end of clutch. Torq/Gard Chain Drives can be used as the driving or driven member. See page 6 for sprocket availability.

1. Place the sprocket on the registered mounting lugs.
2. Select the correct length Hex. Head Cap Screws (3 required) from Table A.

Warning: Short Screws may strip the mounting lug threads.

3. For maximum locking effect, (medium) spring lock washers should be used under the Hex. Head Cap Screws.

Table A–Sprocket Mounting Hardware

TG3/6	TG35A__K	#8-32 X .50 HHCS
TG20	20TG40A__K	#10-24 X .62 HHCS
TG60	TG40A__K	1/4-20 X .75 HHCS
TG200	TG60A__K	3/8-16 X 1.00 HHCS
TG400	TG80A__K	1/2-13 X 1.50 HHCS
TG800	TG100A__K	1/2-13 X 1.75 HHCS

Gear Belt Pulley Installation

Follow the above mounting instructions for the Browning Torq/Gard Gear Belt Pulleys, using the longer Hex. Head Cap Screws supplied with the pulleys.

Chain Coupling Installation

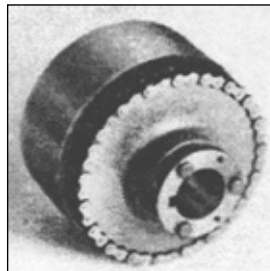

1. Select the Browning Chain Coupling components from page 6 for the applicable Torq/Gard Model.
2. Mount the single strand sprocket per the above "Sprocket Installation" instructions.
3. Place the Split Taper Bushing Sprocket over the Single Sprocket, with the corresponding teeth in alignment.

4. Secure the two sprockets by wrapping the double strand roller chain around the sprockets, insuring that the sprocket teeth fully engage the chain.

5. Insert the chain connecting link in the chain ends and lock with the spring clip (supplied with the connecting link).

When assembled correctly, the Split Taper Bushing Sprocket will “float”, for maximum misalignment capability.

Ever-Flex Coupling Installation



1. Select the correct Ever-Flex Coupling and Adapter Plate from page 6.
2. Attach the Adapter Plate to the Torq/Gard mounting lugs with three (3) Allen Flat Head Cap Screws supplied with the adapter.
3. Mount the Ever-Flex half coupling on the Adapter Plate with the eight (8) Hex. Head Cap Screws supplied with the Adapter Plate.

(Quantity 10 Hex. Head Cap Screws are supplied with Adapter Plate 400CAP9 and 800CAP10.)

Mounting The Torq/Gard



The Torq/Gard Clutch hub is machined to its maximum bore diameter. Shafts smaller than the maximum diameter are accommodated with standard Browning Torq/Gard Bushing Kits as shown on page 6. The bushing kits are complete with bushing, key and shaft set screws.

Note: Six (6) set screws are supplied in four (4) lengths.

Warning: The correct length set screws must be used as the clutch will not release if the set screws extend beyond

the hub and hit the adapter mounting lugs.

The Torq/Gard Clutch can be shaft mounted from the adapter or detector end of the hub. The required shaft set screw lengths vary depending on the bushing selected. They will also vary in length if used on the detector end in conjunction with the detector mechanism.

Tables B, C and D include all set screw combinations for any bushing or mounting option.

Example 1:

A TGC60 Clutch requires a .750 inch diameter shaft mounted on the adapter end.

Selection: A Browning 60BU012 Bushing Kit is chosen from page 6.

The correct set screws from Table B (adapter end):

Qty. 2 .190-32UNF-2A x .50 Long

Qty. 1 .190-32UNF-2A x .19 Long (over key)

Example 2:

A TGC60 Clutch requires a .750 inch diameter shaft mounted on the detector end with the detector mechanism.

Section: A Browning 60BU012 Brushing Kit.

The correct set screws from Table B (detector end):

Qty. 2 .190-32UNF-2A x .75 Long

Qty. 1 .190-32UNF-2A x .38 Long (over key)

NOTE: If the Bushing was used on the detector end without the detector, the selection would be the same as Example 1.

**Table B—TGC60 Clutch
Detector End**

Shaft Dia.	Set Scr. Length (2) Req'd. to Retain Detector Cam	Set Scr. Length (1) Req'd. to Retain Detector Cam Over Key
.750 Dia.	.190-32UNF-2A x .75 Lg.	.190-32UNF-2A x .38 Lg.
.9375 Dia./1.125 Dia.	.190-32UNF-2A x .62 Lg.	.190-32UNF-2A x .38 Lg.
1.250 Dia.	.190-32UNF-2A x .50 Lg.	.190-32UNF-2A x .38 Lg.

Adapter End

Shaft Dia.	Set Scr. Length (2) Req'd. @ Adapter End of Clutch	Set Scr. Length (1) Req'd. Over Key @ Adapter End of Clutch
.750 Dia.	.190-32UNF-2A x .50 Lg.	.190-32UNF-2A x .19 Lg.
.9375 Dia./1.125 Dia.	.190-32UNF-2A x .38 Lg.	.190-32UNF-2A x .19 Lg.
1.250 Dia.	.190-32UNF-2A x .25 Lg.	.190-32UNF-2A x .19 Lg.

**Table C—TGC200 Clutch
Detector End**

Shaft Dia.	Set Scr. Length (2) Req'd. to Retain Detector Cam	Set Scr. Length (1) Req'd. to Retain Detector Cam Over Key
.9375 Dia./1.250 Dia.	.250-20UNC-2A x 1.0 Lg.	.250-20UNC-2A x .50 Lg.
1.250 Dia./1.500 Dia.	.250-20UNC-2A x .88 Lg.	.250-20UNC-2A x .50 Lg.
1.500 Dia./1.750 Dia.	.250-20UNC-2A x .75 Lg.	.250-20UNC-2A x .50 Lg.
1.750 Dia./1.9375 Dia.	.250-20UNC-2A x .62 Lg.	.250-20UNC-2A x .50 Lg.

Adapter End

Shaft Dia.	Set Scr. Length (2) Req'd. @ Adapter End of Clutch	Set Scr. Length (1) Req'd. Over Key @ Adapter End of Clutch
.9375 Dia./1.250 Dia.	.250-20UNC-2A x .75 Lg.	.250-20UNC-2A x .25 Lg.
1.250 Dia./1.500 Dia.	.250-20UNC-2A x .62 Lg.	.250-20UNC-2A x .25 Lg.
1.500 Dia./1.750 Dia.	.250-20UNC-2A x .50 Lg.	.250-20UNC-2A x .25 Lg.
1.750 Dia./1.9375 Dia.	.250-20UNC-2A x .38 Lg.	.250-20UNC-2A x .25 Lg.

**Table D—TGC400 and TGC800 Clutch
Detector End**

Shaft Dia.	Set Scr. Length (2) Req'd. to Retain Detector Cam	Set Scr. Length (1) Req'd. to Retain Detector Cam Over Key
.375 Dia./1.688 Dia.	.375-16UNC-2A x 1.25 Lg.	.375-16UNC-2A x .62 Lg.
1.750 Dia./2.125 Dia.	.375-16UNC-2A x 1.00 Lg.	.375-16UNC-2A x .62 Lg.
2.125 Dia./2.4375 Dia.	.375-16UNC-2A x .88 Lg.	.375-16UNC-2A x .62 Lg.

Adapter End

Shaft Dia.	Set Scr. Length (2) Req'd. @ Adapter End of Clutch	Set Scr. Length (1) Req'd. Over Key @ Adapter End of Clutch
1.375 Dia./1.688 Dia.	.375-16UNC-2A x .88 Lg.	.375-16UNC-2A x .38 Lg.
1.750 Dia./2.125 Dia.	.375-16UNC-2A x .62 Lg.	.375-16UNC-2A x .38 Lg.
2.125 Dia./2.4375 Dia.	.375-16UNC-2A x .50 Lg.	.375-16UNC-2A x .38 Lg.

1. Select the Browning Torq/Gard Bushing Kit from page 6.
2. Refer to tables B, C or D for the correct shaft set screws. (3 required)
3. Slide the bushing with the mating key on the shaft.
Note: The use of LOCTITE C5 - Anti-Seize lubricant is recommended to ease assembly of the bushing to the shaft and the Clutch to the bushing.
4. The shaft length must be at least equal to the bushing length to insure engagement of the Torq/Gard bearings. Limited shaft lengths or high overhung load applications require additional outboard bearing support. Browning Bushings are manufactured specifically to fit the entire length of the hub which provides additional support. Again, check Tables B, C or D to insure that the correct length set screws are used and that they will engage the shaft.
5. Apply Perma-Lok HM118 to the set screws and mating tapped holes in the Clutch hub.

Warning: High inertia loads, reversing loads, excessive vibration or continual tripping may require the use of Perma-Lok HM160.

6. Tighten set screws against shaft and key.

Warning: Check to insure that the set screws do not extend beyond the hub on the adapter end. When used on the detector end the set screws must also engage the detector cam, but must not extend beyond the detector cam.

Overload Detection

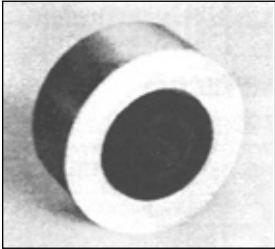

The axial movement of the Detector Mechanism, when used in conjunction with a limit/prox. switch, electrically disconnects the prime mover (motor) from the load.

The Detector Mechanism consists of a spring loaded plate mounted on the clutch cover plate cam. When an overload occurs, the cam releases the detector plate a sufficient distance to

actuate a limit/prox. switch. When the overload has been cleared, the re-engagement of the clutch automatically resets the detector mechanism. **Warning:** Detector systems are recommended on all applications and mandatory on the following:

TG60/TG200 - At speeds over 100 RPM
TG-400/TG800 - At all speeds

Infinitely high shock loads can occur, depending on the type of jam or overload. The detector system further protects your equipment under these conditions. On high inertia applications, breaking the prime mover may have to be considered.

1. The limit/prox. switch must have a rigid mounting.
2. Locate the limit/prox. switch so the detector plate travel will actuate the limit/prox. switch.

Note: Refer to Figure 1 and Figure 2 for typical installations. Figure 1 mounting is preferred for reasons of rigidity.

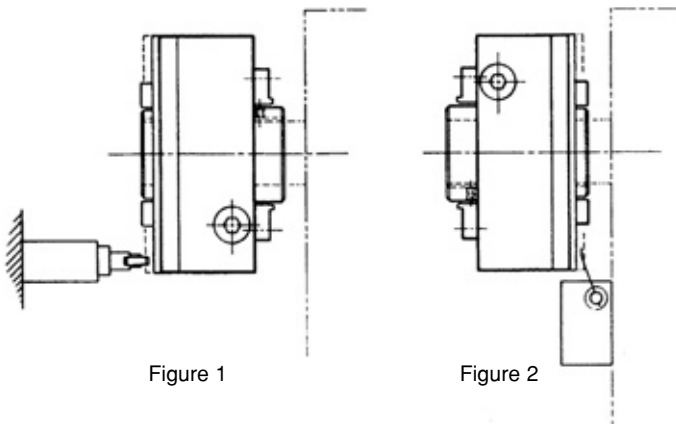

3. Refer to the Torq/Gard dimension prints on page 5 for the detector plate "travel".
4. When mounting the limit/prox. switch, consult the manufacturer's specifications for pre-travel and overtravel.
5. Wire the limit/prox. switch in parallel with the "start" contactor to permit motor starting after the overload has been cleared.

Note: Refer to Figure 3 "Typical Wiring Diagram". Limit/prox. Switches are available with additional contacts to further actuate warning alarm systems.

Typical Wiring Diagram

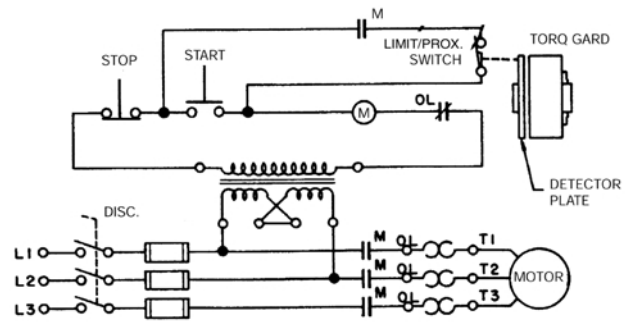

Figure 3

6. The detector mechanism can be installed in the field.
 - A. Place the three (3) detector springs in the three shallow holes in the Torq/Gard cover.
 - B. Place the "white" detector plate guide pins in the three deep holes in the cover.

Note: The pins are registered to fit in one position only.
 - C. Place the "black" detector cam on the clutch hub with flat side up.
 - D. Rotate the cam until each cam lobe is directly over the detector plate ears and the set screw holes are aligned with the set screw holes in the hub.

Note: The clutch must be in its engaged position for proper alignment of the detector mechanism.
 - E. Secure the detector cam to the clutch hub with the correct length set screws, using Perma-Lok HM118. (Refer to Tables B, C or D for the correct shaft set screws.)

Warning: Factory mounted detector mechanisms utilize set screws for shipping purposes only. The correct length of the set screws is determined by the shaft diameter used.

Torque Setting

The torque is infinitely adjustable within the nameplated torque limits of the clutch. Determine the operating and tripping torque required to drive your machine.

- A. Operating torque is the normal full load torque required by the application.
- B. Tripping torque, which is usually higher than operating torque, depends on the starting torque requirements of the application and the location of the Torq/Gard Clutch.
- C. Mounting the clutch away from the motor tends to absorb peak starting torques through power transmission and machine components. (Refer to Fig. 4.)
- D. Tripping torque should be set higher than the point at which the clutch will "nuisance trip" on starting, but below the maximum torque value the machine can safely absorb.

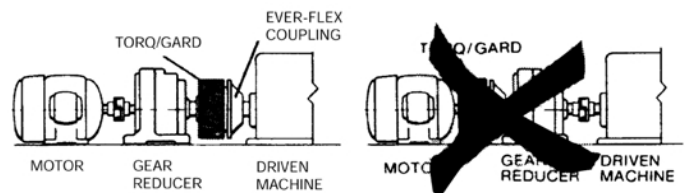
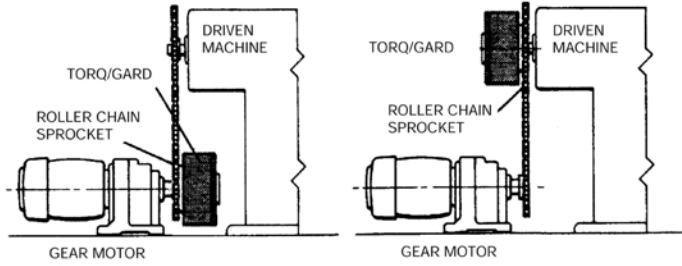

Figure 4

Direct Drive application with the Torq/Gard mounted on the low speed output shaft of the reducer. The Torq/Gard is shown with a Browning Ever-Flex half coupling which mounts on the clutch adapter without modification. Browning Chain Coupling Kits are also available for the Torq/Gard when greater misalignment capabilities are required. Either side of the Torq/Gard can be used as the input.

The Torq/Gard should not be used on the high speed input side of the reducer. Clutch sensitivity becomes a function of the reducer's gear ratio. As an example, when used with a 100 to 1 reducer, a 100 inch-pound torque variation on the output side will reflect only a 1 inch-pound change on the input side. Do not exceed the maximum RPM shown in the Torq/Gard selection table.



Mounting the clutch on the output of the gear motor or reducer provides the most economical clutch assembly. The Torq/Gard is designed to protect the weakest link in the drive system.

The Torq/Gard is mounted on the driven machine and powered through a chain and sprocket drive. Mounting the clutch in this position tends to absorb peak starting torques.

The Torq/Gard Clutch is delivered with the torque set at the low end of its torque range.

1. Turn the single Hex.-Socket Head adjusting nut clockwise to increase the Torque Setting. (Refer to Table E.) Note: 1/2 inch Hex-Keyed (Allen) Wrench is required.

Table E

MODEL	APPROXIMATE TORQUE (IN.-LBS.) PER TURN		MAXIMUM TURNS
	Min.	Max.	
TG-3	2.67	7.5	7.5
TG-6	4.4	7.5	7.5
TG-20	11	13	13
TGC60	50	8	8
TGC200	100	11	11
TGC400	225	9	9
TGC800	450	9	9

2. Sighting the front face of the adjusting nut with the Torque Meter Lines on the nameplate indicates the approximate torque setting.

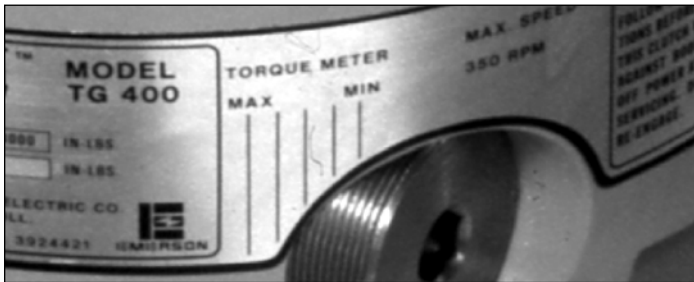

3. The "Min." line on the nameplate is the point at which the adjusting nut is threaded. Before setting the torque, Perma-Lok HM118 should be applied to the exposed threads.
4. The first line on the Torque Meter beyond "Min." represents the low torque setting.

Warning: The clutch should not be operated at torque settings below this "line".

5. Do not set torque if the clutch is disengaged as an erroneous torque setting will result.

Warning: Do not remove the adjusting nut. Extremely fine threads are used to reduce the possibility of the adjusting nut losing its setting. If the adjusting nut is removed for any reason, (including lubrication) upon replacing, hand thread the first few turns or cross threading may occur.

Tripping torque can be established by progressively increasing the torque setting until the clutch no longer trips under starting loads.

If the tripping torque value is known, the clutch may be pre-set with a torque wrench or a torque arm and calibrated spring scale.

The Torq/Gard may also be sized by applying one of the following formulas:

$$\text{Torque (In.-lbs.)} = \frac{\text{Horsepower (HP)} \times 63025}{\text{RPM}}$$

$$\text{OR Horsepower} = \frac{\text{Torque (In.-lbs.)} \times \text{RPM}}{63025}$$

Tripping Torque = Operating Torque x Service Factor

Note: The nameplate contains a sensitized "rectangle" on which the torque setting may be recorded with ball point pen or a numbering die.

Warning: The Torq/Gard Clutch is not a "FAIL SAFE" device and cannot be used on "overhauling" or "holding" load applications.

TORQ / GARD RATINGS

Models	Torque (in.-lbs.)		HP Max.	RPM Max.	Weight (lbs.)	Inertia (WK2)	Bore Dia. Max. (inches)
	Min.	Max.					
TG-3	13	32	1.5	1800	1.5	1.4	1/2
TG-6	23	56	2.5	1800	1.5	1.4	1/2
TG-20	56	203	4	1800	2.5	5.7	3/4
TGC 60	200	600	8.5	900	5.5	10	1-1/4
TGC 200	600	2000	21.5	680	12	46	1-15/16
TGC 400	2000	4000	22.2	350	38	455	2-7/16
TGC 800	4000	8000	44.4	350	38	455	2-7/16



Automatic Reset

The Torq/Gard Clutch is automatically reset by "jogging" the motor after the overload has been corrected. At speeds under 50 RPM the Torq/Gard will re-engage, without jogging, upon starting the motor. The clutch will not re-engage if the overload exceeds the torque setting.

Warning: Do not re-engage the Torq/Gard manually. When the clutch snaps into engagement, injury could occur if the operator's hand is near a chain and sprocket or belt drive.



Single Position

The Torq/Gard always resets in the same position when tripped. It is an excellent choice in applications that must remain registered or timed. All Torq/Gard Clutches are fully reversible.

Lubrication

The Torq/Gard is factory lubricated with Mobilith AW2 and does not require additional lubrication for many years, under normal operating conditions.

Clutches used in extreme operating applications may be opened for regreasing.

Open clutch for greasing by removing torque adjusting nut, detector system, cover bolts and then tap hub end opposite cover with a soft hammer. "Do not pry open at cover split line".

Apply grease (AW2 or equiv.) to hub bearing journals, hub cam track, follower, thrust washer surfaces and all needle bearings.

torq/gard™

TGC 60

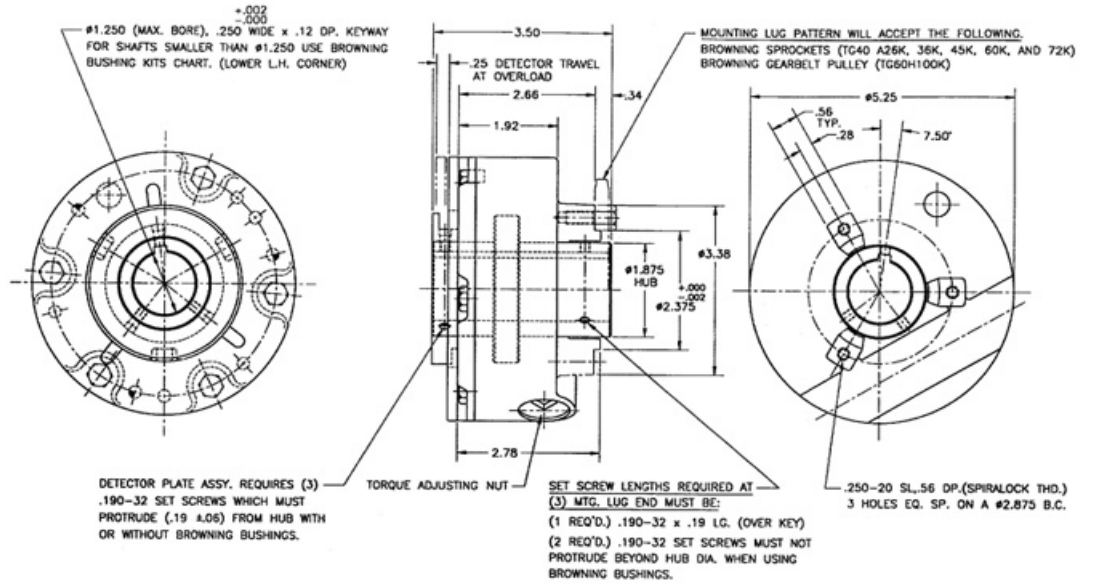

TGC 200

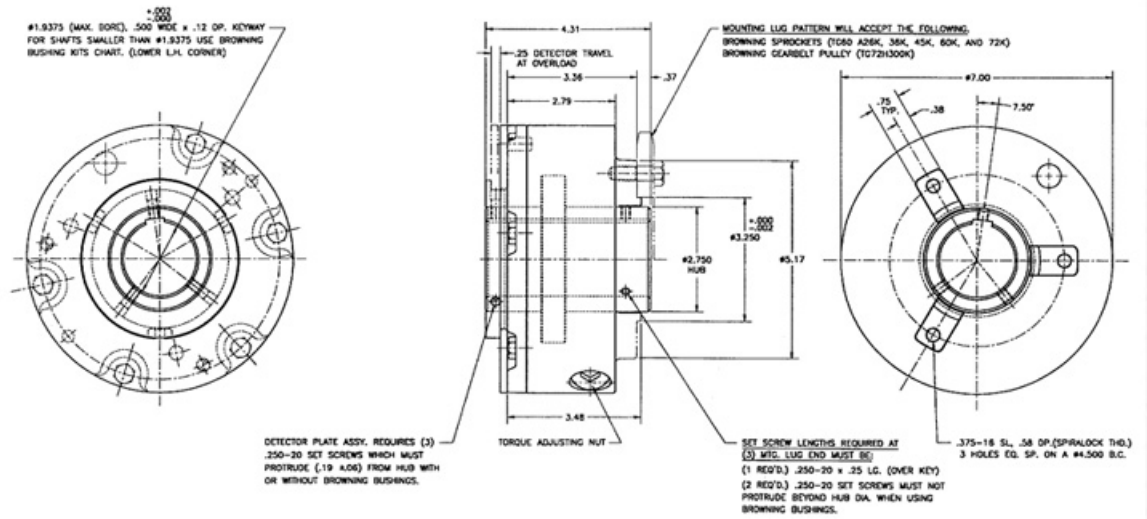

TGC 400 and 800

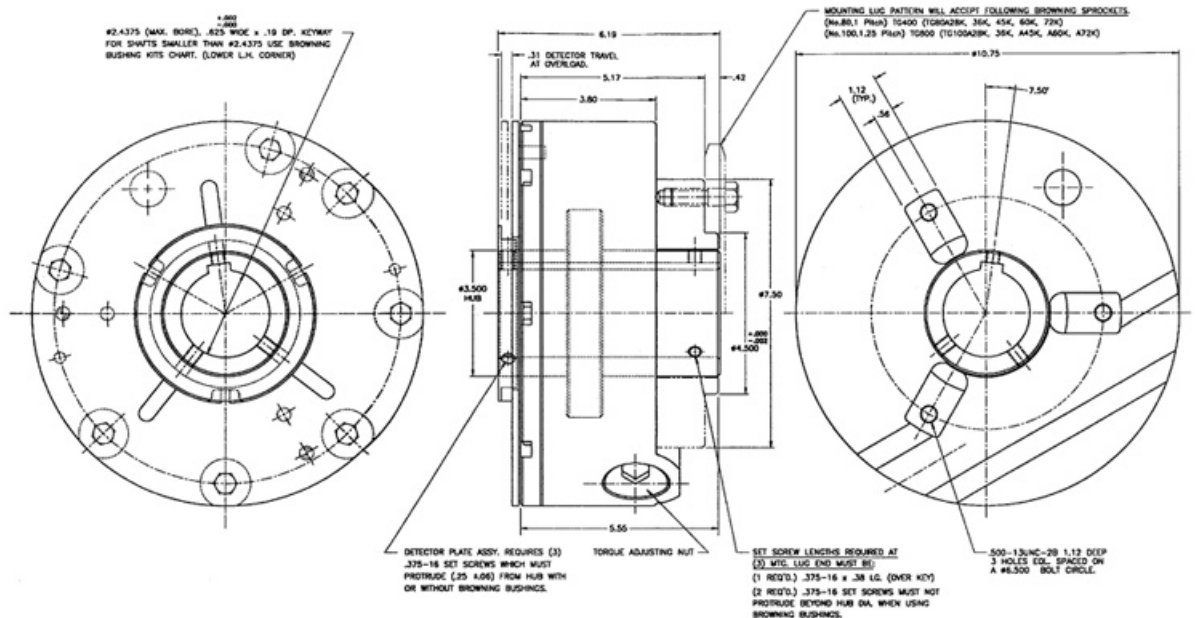

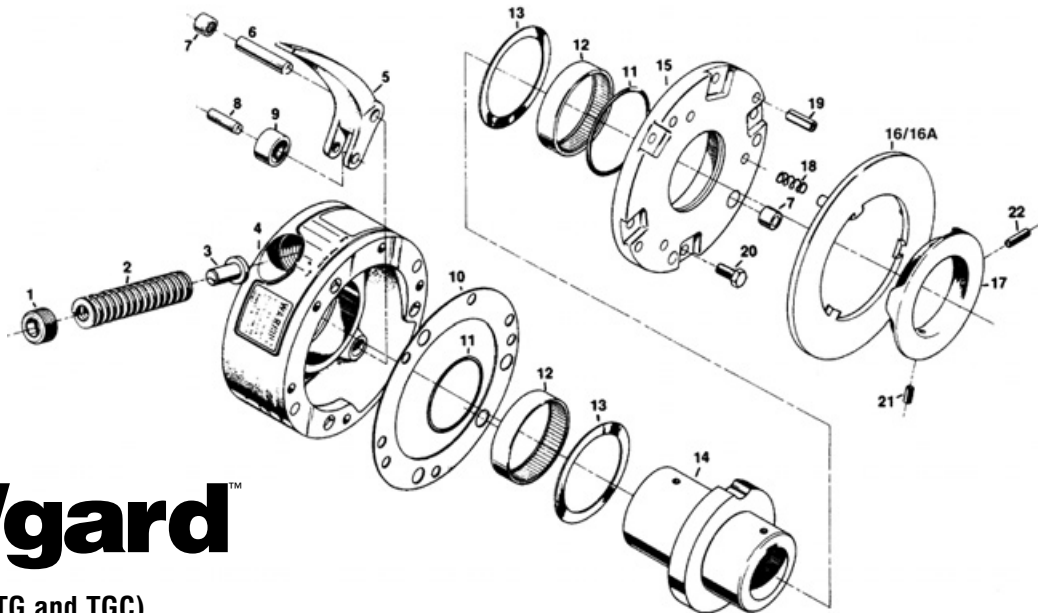

torq/gard™

Parts List (Models TG and TGC)

Item	Qty	Description	PART NUMBER						
			3	6	20	60	200	400	800
1	1	Adjusting Nut	A-58211	A-58211	A-58238	A-16512	A-16346	B-16680	B-16680
2	1	Spring	A-58255-1	A-58255-2	A-58255-3	A-15731	A-13732	A-16682-1	A-17538-1
2	1	Spring	-	-	-	-	-	A-16682-2	A-17538-2
3	1	Button	A-58168	A-58168	A-58171	A-15727	A-13407	A-16685	A-16685
4	1	Body	D-58675	D-58675	C-58695	D-65632	D-65927	D-18715	D-18715
5	1	Lever	B-58202	B-58202	B-58236	B-16510	C-13401	C-16677	C-16677
6	1	Dowel Pin	A-58159	A-58159	A-58165	A-17647	A-17648	A-26007-89	A-26007-89
7	2	Bearing	A-61684	A-61684	A-61687	B-15732-1	A-14407	B-15732-4	B-15732-4
8	1	Dowel Pin	A-58158	A-58158	A-58164	A-17650	A-26007-37	A-26007-65	A-26007-65
9	1	Bearing	A-61685	A-61685	A-61688	A-15730-1	A-14409	A-16683	A-16683
10	1	Gasket	A-58173	A-58173	B-58181	B-73040	C-73044	C-16679	C-16679
11	2	O-Ring	A-58182-1	A-58182-1	A-58182-2	A-15729-2	A-14399	A-15729-3	A-15729-3
12	2	Bearing	A-61683	A-61683	A-61686	B-15732-3	A-14408	B-15732-5	B-15732-5
13	2	Thrust Washer	A-58172	A-58172	A-58174	A-16511	B-13406	B-16681	B-16681
14	1	Drive Hub	B-58609	B-58609	B-58668	B16506	C-76760	D-18719	D-18719
15	1	Cover	B-58250	B-58250	B-58260	C-65649	D-65879	D-16675	D-16675
16	1	Detector Plate	B-58794	B-58794	B-58383	B17056	C-16927	C-17076	C-17076
16A	1	Prox Detector Plate Assy	-	-	-	B-71122	C-71123	C-71126	C-71126
17	1	Cam-Detect Plate	B-58795	B-58795	B-58385	B-17055	B-76762	C-17077	C-17077
18	3	Spring	A-53740-4	A-53740-4	A-53052-4	A-17059	A-16989	A-17788	A-17788
19	2	Roll Pin	A-26023-35	A-26023-35	A-26023-37	A-73403-1	A-73403-2	A-26023-71	A-26023-71
20	5	Hex HD Cap Screw	A-26015-17	A-26015-17	A-26015-23	A-18874-2	A-26002-15	-	-
20	7	Hex HD Cap Screw	-	-	-	-	-	A-18876-2	A-18876-2
21	1	Soc HD Set Screw	A-26005-16	A-26005-16	A-26005-16	A-26005-39	A-26005-45	A-26005-77	A-26005-77
22	2	Soc HD Set Screw	A-26005-17	A-26005-17	A-26005-17	A-26005-40	A-26005-46	A-26005-79	A-26005-79

SINGLE STRAND SPROCKETS ANSI Standard Roller Chain FOR NO. 40, 1/2" PITCH

Model	Sprocket Part No.	No. Teeth
TGC60	TG40A26K	26
	TG40A36K	36
	TG40A45K	45
	TG40A60K	60
	TG40A72K	72

FOR NO. 60, 3/4" PITCH

Model	Sprocket Part No.	No. Teeth
TGC200	TG60A26K	26
	TG60A36K	36
	TG60A45K	45
	TG60A60K	60
	TG60A72K	72

FOR NO. 80, 1" PITCH

Model	Sprocket Part No.	No. Teeth
TGC400	TG80A28K	28
	TG80A36K	36
	TG80A45K	45
	TG80A60K	60
	TG80A72K	72

FOR NO. 100, 1-1/4" PITCH

Model	Sprocket Part No.	No. Teeth
TGC800	TG100A28K	28
	TG100A36K	36
	TG100A45K	45
	TG100A60K	60
	TG100A72K	72

TORQ / GARD BUSHING KITS

Model	Shaft Dia.	Bushing Kit No.	Model	Shaft Dia.	Bushing Kit No.	Model	Shaft Dia.	Bushing Kit No.
TGC60	3/4	60BU012	TGC200	15/16	200BU015	TGC400 AND TGC800	1-3/8	800BU106
	15/16	60BU015		1	200BU100		1-7/16	800BU107
	1	60BU100		1-1/16	200BU101		1-1/2	800BU108
	1-1/8	60BU102		1-1/8	200BU102		1-5/8	800BU110
	1-1/4	NONE		1-3/16	200BU103		1-11/16	800BU111
	20mm	60BU020mm		1-1/4	200BU104		1-3/4	800BU112
	25mm	60BU025mm		1-5/16	200BU105		1-7/8	800BU114
	28mm	60BU028mm		1-3/8	200BU106		1-15/16	800BU115
		1-7/16	200BU107	2	800BU200			
		1-1/2	200BU108	2-1/8	800BU202			
		1-5/8	200BU110	2-3/16	800BU203			
		1-11/16	200BU111	2-1/4	800BU204			
		1-3/4	200BU112	2-7/16	NONE			
		1-15/16	NONE					

TORQ / GARD CHAIN COUPLING KITS

Model	Single Strand Sprocket Part No.	Single Sprocket For Split Taper Bushing Part No.	Coupling Chain w/link Part No.
TGC60	TG40A26K	40P26	C4026
TGC200	TG60A26K	60P26	C6026
TGC400	TG80A28K	80028	C8028

TORQ / GARD GEARBELT PULLEYS FOR 1/2" PITCH BELTS

Model	A Part No.	Pitch Dia.	No. of Grooves	Belt Width
TGC60	TG60H100K	9.549	60	1"
TGC200	TG72H300K	11.459	72	3"

EVER-FLEX COUPLINGS

Model	Coupling Half Part No.	Adapter Plate Part No.	Split Taper Bushing
TGC60	CHCFR5H	C18639	H
TGC200	CHCFR8P	C18640	P1
TGC400	CHCFR9Q	C18641	Q1
TGC800	CHCFR10Q	C18642	Q1

CLUTCHES & PARTS STOCK BY:

R.M. HOFFMAN COMPANY
159 SAN LAZARO AVE.
SUNNYVALE CA 94086

CALL: 408 739-6580
FAX 408 735-1158

ORDER ON LINE:
WWW.RMHOFFMAN.COM

METAL DETECTOR PLATES IN STOCK!

Industrial Motion Control, LLC 1444 S. Wolf Road, Wheeling, IL 60090 Phone: 847-459-5200 Fax: 847-459-3064



www.camcoindex.com



The Driving Force in Automation



www.ferguson-co.com

Michigan Office
550 Forest Avenue Unit #14
Plymouth, MI 48170
USA
ph: 734-459-8080
fax: 734-459-8110

UK Office
432 Perth Avenue
Slough Trading Estates
Slough, Berkshire SL14TS
England
ph: 753-786100
fax: 753-786101

Belgium Office
33 Parc Industriel
BI 440 Braine-le-Château
Brussels, Belgium
ph: 332-367-1311
fax: 332-366-1891